



ISO-MIX®

Ahead in technology



IM 10

IM 10 Rotary Jet Head mixer

The patented IM 10 is a Rotary Jet Head mixer which provides fast and efficient, hydraulically-balanced mixing in tanks. It can also be used for efficient gas dispersion, and it is the most efficient CIP tank-cleaning machine on the market.

Applications

The IM 10 is typically used in process and storage vessels of volume 1 – 10 m³ used in the food industry, the beer and beverage industry, the biotech/pharma industry, the chemical industry, and other industries where liquid mixing and/or gas dispersion are central.

The IM 10 is only used in liquids containing no fibrous or abrasive particles.

Operation

The liquid to be mixed is circulated from the tank via a pump to the IM 10 which is positioned under the liquid surface. The liquid flow is used to drive a gearing system which makes the nozzles of the IM 10 rotate around both the horizontal and vertical axes.

When small volumes are mixed with a large liquid volume, the IM 10 is most efficient if the liquid to be mixed into the large liquid volume is added in the recirculation loop at the suction side of the pump.

In gas dispersion applications, gas is added on the pressure side of the pump.

A heat exchanger can be installed in the recirculation loop, providing efficient heat transfer and temperature control.

Benefits

Using the IM 10 Rotary Jet Head mixer makes it possible, at a modest investment, to perform fast and efficient mixing in a sanitary system. In traditional systems, using impeller mixers, a rotating shaft penetrates the tank wall, and a mechanical seal and a gear box are installed. With the ISO-MIX system the shaft, seal and gearbox are eliminated, and a more sanitary design is obtained.

With impeller mixers it is difficult to achieve good mixing without introducing baffles in the tank. However, if efficient cleaning-in-place is required, baffles make the job difficult. Hence in e.g. the food industry and in the beer and beverage industry they are normally avoided. With the Rotary Jet Head mixing technology good mixing is achieved without the use of baffles.

The ISO-MIX Rotary Jet Head can also be used for gas dispersion.

The IM 10 can furthermore be used for efficient CIP when the tank is empty, saving liquid, chemicals and energy compared to a fixed spray ball CIP system.

Standards

The IM 10 is manufactured in accordance with ISO 9001 standards and complies with the ATEX directive.

ISO-MIX A/S

Baldershøj 28
DK-2635 Ishøj
Denmark

Phone +45 43 30 31 00
Fax +45 43 30 31 01

www.iso-mix.com

The ISO-MIX technology

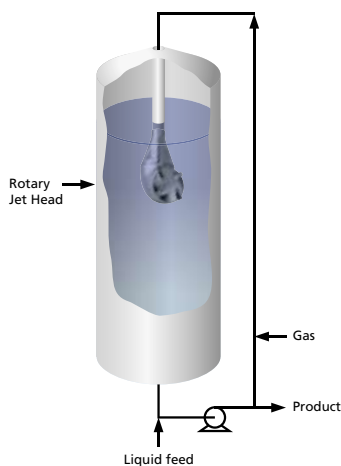

Traditional mixing technology

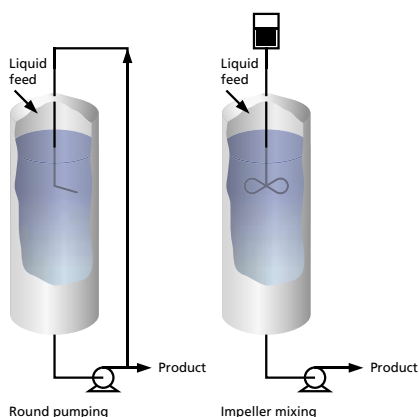



ISO-MIX®

Ahead in technology

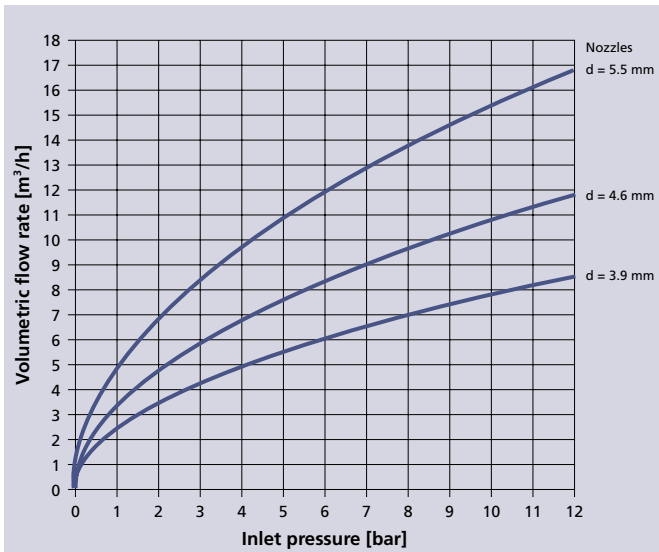

Flow Rate

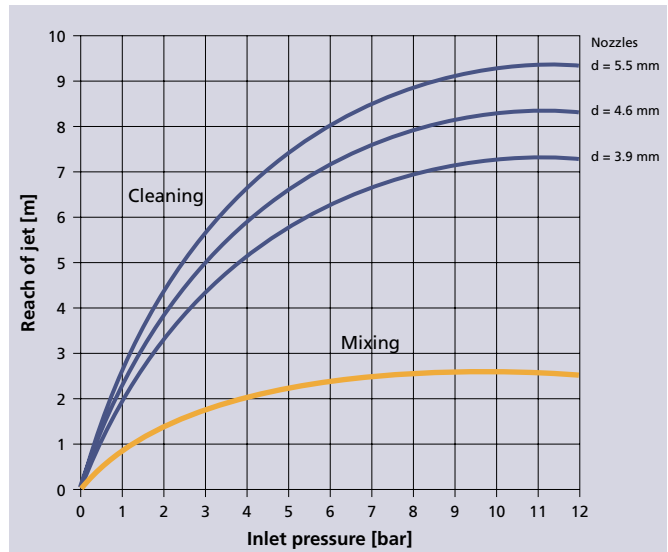

Reach of jet

Relationship between inlet pressure and flow rate for liquids with water-like properties for the IM 10 Rotary Jet Head.

Reach of jet for the IM 10 during cleaning, and indicative reach of jet for mixing of liquids with water-like properties.

Dimensions [mm]

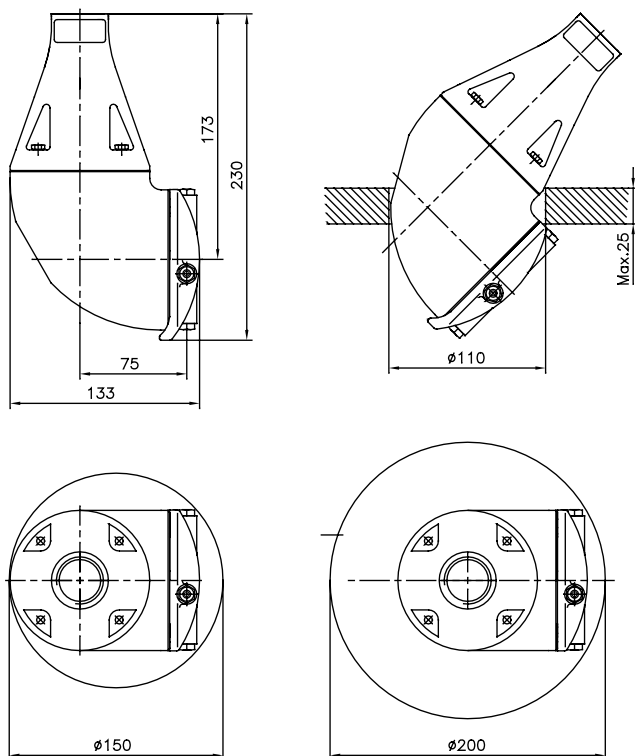

Specifications

Materials: AISI 316L, AISI 316, SAF 2205 (UNS 31803), EPDM, PEEK, PVDF, PFA, Ceramics

Weight: 5.1 kg (11.2 lbs)

Lubricant: Self-lubricating with the mixing/cleaning fluid

Working pressure: 2 - 8 bar (28 - 114 psi)

Recommend pressure during mixing: 2-6 bar (28 - 85 psi)

Recommended pressure during CIP: 4-8 bar (57 - 114 psi)

Max. working temperature: 110°C (225°F)

Max. ambient temperature: 140°C (284°F)

Standard thread: 1" BSP or NPT, female, Top cone 1" BSP with sanitary seal

Min. tank opening: See dimension drawings